

WG128128C Graphic 128x128 dots

Dimension drawing

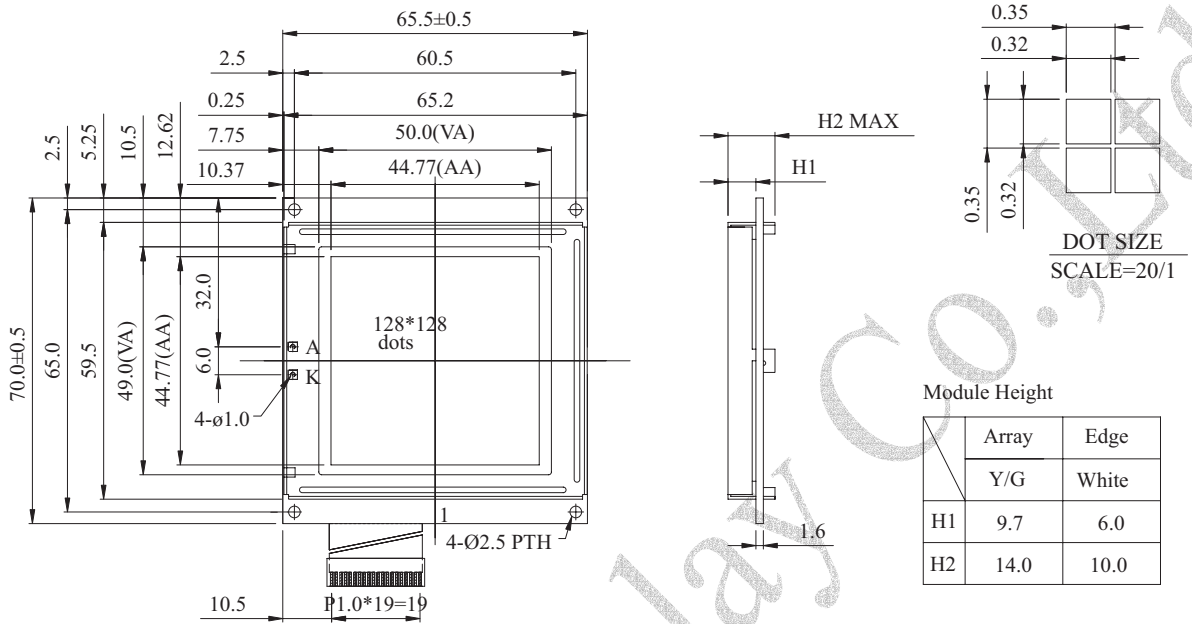

Graphic type

Feature

1. Built-in controller Toshiba-(T6963 or Equivalent)
2. 1/128 duty cycle
3. +5V power supply
4. No Negative Voltage Option

Mechanical Data

Item	Standard Value	Unit
Module Dimension	65.5x70.0	mm
Viewing Area	50.0x49.0	mm
Dot Size	0.32x0.32	mm
Mounting hole	0.35x0.35	mm

Absolute Maximum Rating

Item	Symbol	Standard Value			Unit
		min.	typ.	max.	
Power Supply	VDD-VSS	4.75	5.0	5.25	V
Input Voltage	VI	-0.3	---	VDD	V

Note: VSS=0 Volt , VDD=5.0 Volt .

Electrical Characteristics

Item	Symbol	Condition	Standard Value			Unit
			min.	typ.	max.	
Input Voltage	VDD	---	4.75	5.0	5.25	V
Supply Current	IDD	VDD=5V	4.5	5.8	7.0	mA
Recommended LC Driving Voltage for Normal Temp. Version module	VDD-V0	-20°C	16.2	16.7	17.2	V
		0°C	15.8	16.2	16.7	
		25°C	15.0	15.8	16.2	
		50°C	14.6	15.0	15.8	
		70°C	14.2	14.6	15.0	
LED Forward Voltage	VF	25°C	---	4.2	4.6	V
LED Forward Current	IF	25°C	---	---	---	mA
EL Power Supply Current	IEF	Vel=110VAC;400Hz	---	---	5.0	mA

Pin NO.	Symbol	Function
1	Vss	Ground
2	Vdd	Power supply (+5V)
3	Vo	Power supply for driving
4	/WR	Data write
5	/RD	Data read
6	/CE	Chip enable the controller T6963C
7	C/D	WR=L,C/D=H:Command C/D=L:data write RD=L,C/D=H>Status Read C/D=L: data read
8	RESET	L: reset signal
9	DB0	Data bus line
10	DB1	Data bus line
11	DB2	Data bus line
12	DB3	Data bus line
13	DB4	Data bus line
14	DB5	Data bus line
15	DB6	Data bus line
16	DB7	Data bus line
17	FS	Pins for selection of font; H:6*8,L:8*8
18	NC	NO connection
19	A	Power supply for LED B/L(+4.2V)
20	K	Power supply for LED B/L(0V)