

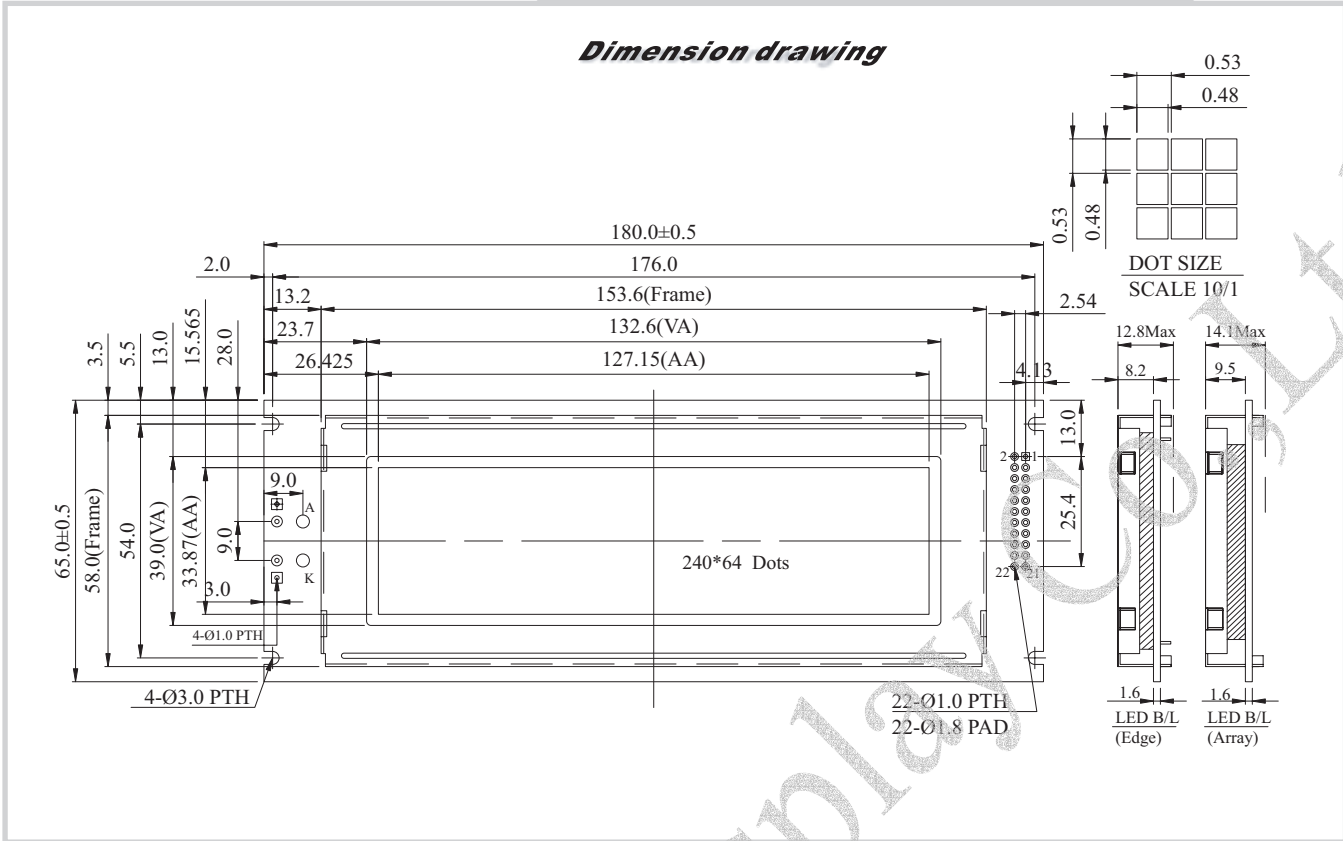

WG24064J Graphic 240x64 dots

Dimension drawing



Feature

1. Built-in controller TOSHIBA-(T6963C or Equivalent)
2. 1/64 duty cycle
3. +5.0V power supply
4. Built-in N/V

Mechanical Data

Item	Standard Value	Unit
Module Dimension	180.0x65.0	mm
Viewing Area	132.6x39.0	mm
Dot Size	0.48x0.48	mm
Dot Pitch	0.53x0.53	mm
Mounting hole	176.0x54.0	mm

Absolute Maximum Rating

Item	Symbol	Standard Value			Unit
		min.	typ.	max.	
Power Supply	VDD-VSS	4.75	5.0	5.25	V
Input Voltage	VI	-0.3	---	VDD	V

Note: VSS=0 Volt , VDD=5.0 Volt .

Electronical Characteristics

Item	Symbol	Condition	Standard Value			Unit
			min.	typ.	max.	
Input Voltage	VDD	---	---	5.0	---	V
Supply Current	IDD	VDD=5V	---	17.3	---	mA
Recommended LC Driving Voltage for Normal Temp. Version module	VDD-VO	-20°C	---	---	---	V
		25°C	---	14.6	---	
		70°C	---	---	---	
CCFL Starting Voltage	VFLS	25°C	---	---	---	Vrms
CCFL Driving Voltage	VFLD	25°C	---	---	---	Vrms
CCFL Driving Current	IFLD	VFQ=450Vrms 30KHZ	---	---	---	mA rms
LED Forward Voltage (Array)	VF	25°C	---	4.2	---	V
LED Forward Voltage (Edge)	VF	25°C	---	2.1	---	V
LED Forward Current	IF	25°C	---	660	---	mA
EL Power Supply Current	IEF	Vel=110VAC;400Hz	---	---	5.0	mA

Pin NO.	Symbol	Function
1	FG	Frame ground
2	VSS	GND
3	VDD	Power supply
4	VO	Contrast Adjustment
5	/WR	L: Data write
6	/RD	L: Data read
7	CE	Enable signal
8	C/D	WR=L, C/D=H: Command Write C/D=L: Data write RD=L, C/D=H: Status Read C/D=L: Data read
9	NC	NC
10	RESET	H: Normal ; L: Initialize T6963C
11	DB0	Data Bus line
12	DB1	Data Bus line
13	DB2	Data Bus line
14	DB3	Data Bus line
15	DB4	Data Bus line
16	DB5	Data Bus line
17	DB6	Data Bus line
18	DB7	Data Bus line
19	FS	Pins for selection of font; H: 6 * 8 , L: 8 * 8
20	VOUT	Contrast Adjustment
21	SLA	Power supply for B/L(+)
22	SLK	Power supply for B/L(-)

Graphic type