

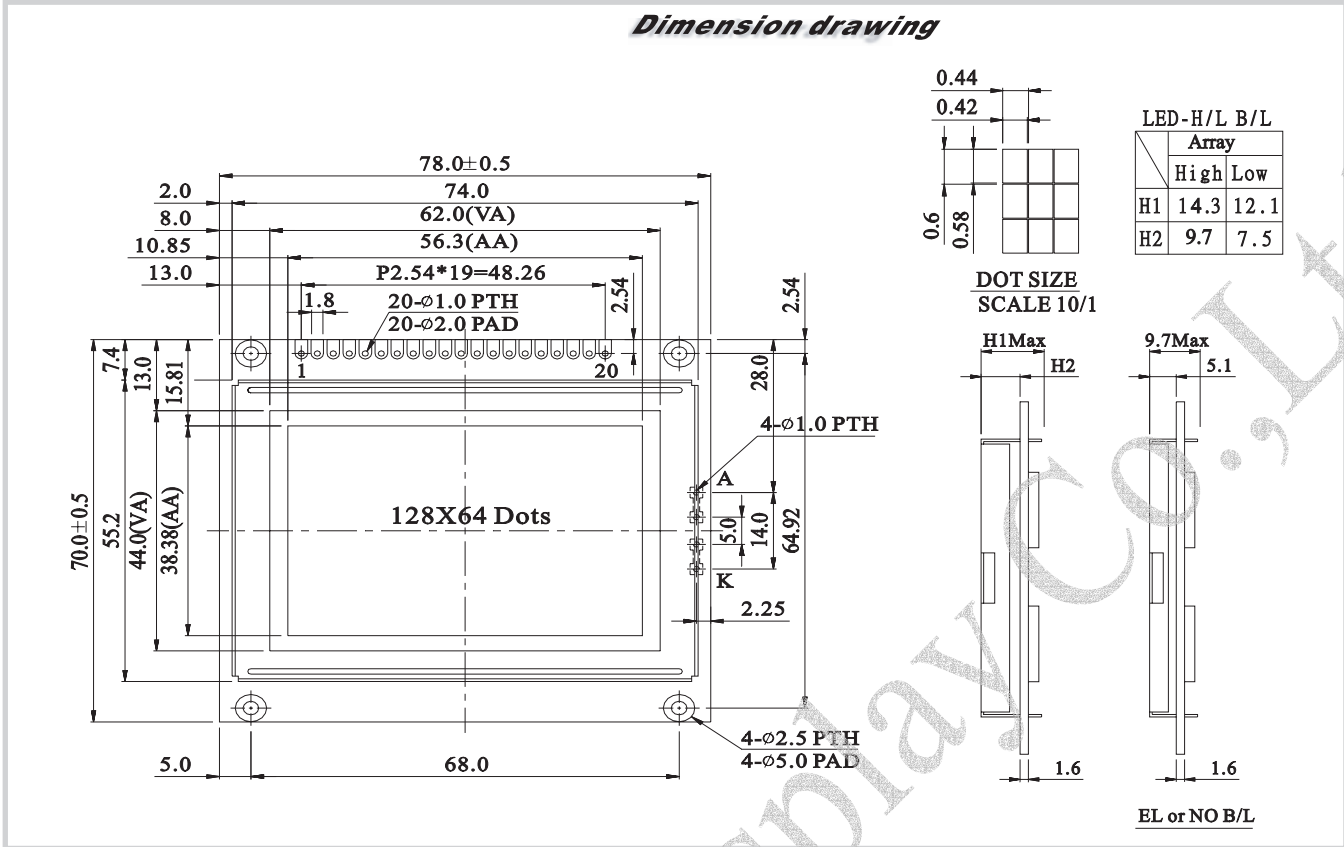

WG12864C Graphic 128x64dots

Dimension drawing



Feature

1. Built-in controller Samsung-(KS0107 · KS0108 or Equivalent)
2. +5V power supply
3. 1/64 duty cycle
4. N.V. Built-in

Mechanical Data

Item	Standard Value	Unit
Module Dimension	78.0x70.0x14.3	mm
Viewing Area	62.0x44.0	mm
Mounting hole	68.0x 64.92	mm
Dot pitch	0.44x0.60	mm

Pin NO.	Symbol	Function
1	CS1	Chip select for IC1
2	CS2	Chip select for IC2
3	Vss	GND
4	Vdd	Power supply (+5V)
5	Vo	Contrast Adjustment
6	D/I	Data/Instruction
7	R/W	Data read/write
8	E	H→L Enable signal
9	DB0	Data bus line
10	DB1	Data bus line
11	DB2	Data bus line
12	DB3	Data bus line
13	DB4	Data bus line
14	DB5	Data bus line
15	DB6	Data bus line
16	DB7	Data bus line
17	RST	Reset
18	Vee	Negative voltage output
19	A	Power supply for LED+(4.2V)RA=0Ω
20	K	Power supply for LED (0V)

Absolute Maximum Rating

Item	Symbol	Standard Value			Unit
		min.	typ.	max.	
Power Supply	VDD-VSS	4.5	5.0	5.5	V
Input Voltage	VI	-0.3	---	VDD	V

Note : VSS=0 Volt, VDD=5.0 Volt.

Electronical Characteristics

Item	Symbol	Condition	Standard Value			Unit
			min.	typ.	max.	
Input Voltage	VDD	L level	0.7VDD	---	VDD	V
	VIO	H level	0	---	0.3VDD	V
Supply Current	IDD	VDD=5V	---	3.5	---	mA
Recommended LC Driving Voltage for Normal Temp. Version module	VDD-V0	-20°C	9.6	10.1	10.6	V
		0°C	9.4	9.9	10.4	
		25°C	9.4	9.6	10.4	
		50°C	9.4	9.2	9.7	
		70°C	9.2	9.0	9.5	
LED Forward Voltage	VF	25°C	---	4.2	4.6	V
LED Forward Current	IF	25°C Array High	---	480	960	mA
		Low	---	140	280	mA
EL Power Supply Current	IEL	Vel=110VAC;400Hz	---	---	5.0	mA

Graphic type